

SCREEN

ADVANCING THE FUTURE OF PRINT

PlateRite 8300

Thermal Plate Recorders

CTP



The versatility and performance you need for your pressroom

Why is thermal computer-to-plate (CTP) technology the system of choice for so many successful companies? There's no doubt about thermal CTP's reliable high-quality output. It is unrivalled for its superb sharp dots. Whenever quality is crucial, the natural choice is thermal. Its consistency for long run lengths and easy daylight handling are also important for many printers. And the bottom line is always about keeping the presses running.

The PlateRite 8300S and PlateRite 8300E are state-of-the-art thermal CTP recorders. They deliver the versatility and productivity you need to keep your presses running. And they can do this for any plate format from B3 to B1 size.

Both also offer optional inline plate punching for perfect on-press register and faster makeready times, as well as Screen's acclaimed autoloader options for unattended plate loading. If you like the idea of running your pressroom at full capacity, you'll love the PlateRite 8300S and PlateRite 8300E.



Advanced Technology

Versatility and productivity

Unrivalled Print Quality

The PlateRite 8300S features a 32-channel light source, and combined with a high speed rotating drum, provides output at a blistering 13 plates* per hour. For a more economical choice, the PlateRite 8300E utilizes a 16-channel light source and is capable of outputting 8 plates* per hour.

Experience the exceptional screening reproduction that only thermal plate recorders can deliver. You have a choice of 2 advanced models to suit all your production requirements.

* 1,030 x 800 mm plate size at 2400 dpi.

Model	PlateRite 8300S	PlateRite 8300E
Plates per hour	13	8
Imaging head	32 channels	16 channels
Plate sizes	B3 to B1	

Suitable for a wide range of plate sizes

The PlateRite 8300S and PlateRite 8300E are suitable for use with a wide range of plate sizes, from 450 x 370 mm (17.8" x 14.6") (GTO size) to 1,160 x 940 mm (45.6" x 37"), and plate thicknesses between 0.15 and 0.3 mm (5.9 and 11.8 mil). They are compatible with plates up to 0.4 mm thick as a factory option. By popular request, they are now also compatible with B3 vertical size plates.

As a factory option, a plate size of 304 x 370 mm (12.0" x 14.6") can be supported on both models.

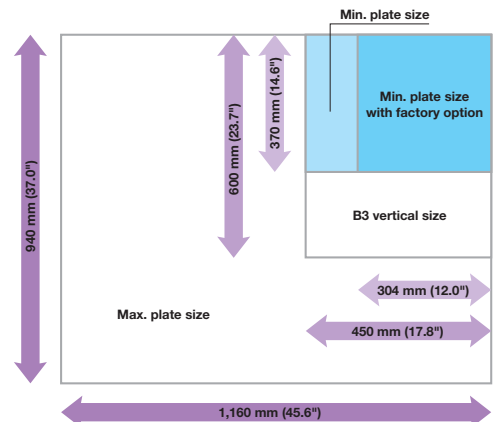

Advanced external drum design

The thermal PlateRite series is constructed with a reliable external drum design. This makes it possible for the drum to spin at high speeds with the imaging head positioned close to the surface of the plate. Easy maintenance of the imaging head is another key advantage of this design. Individual laser diodes can be replaced as required.

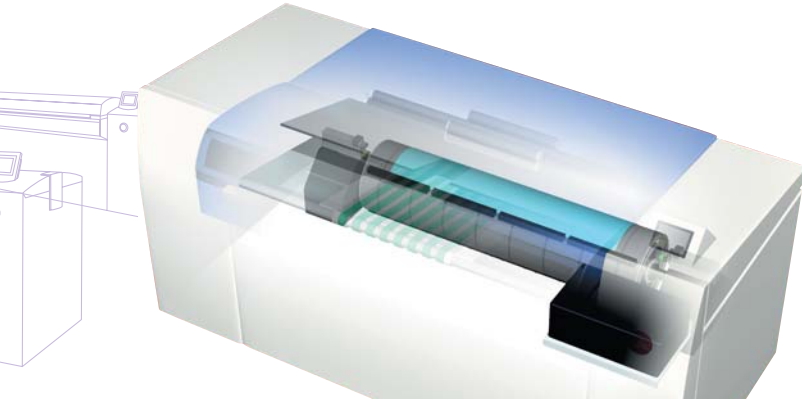

Providing you with the perfect CTP upgrade environment

To meet your expanding production requirements, we have made it easy to upgrade the PlateRite 8300E to the 8300S by simply replacing certain key parts. This eliminates excess costs and increases operating efficiency.

Intelligent auto-balance system

Thanks to this auto-balance system, no manual adjustments are required for drum balance when switching to a different sized plate. All you need to do is select the plate size from the display menu and the auto-balance system automatically optimizes the balance of the recording drum.

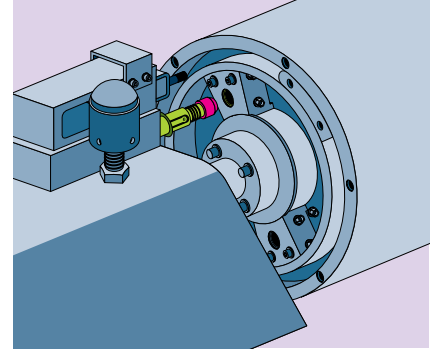

State-of-the-art plate-securing system

The PlateRite 8300S and PlateRite 8300E feature an automated clamping and vacuum system. This system can reliably and firmly secure a wide range of plate sizes, even for fast-rotation/high-speed exposure.

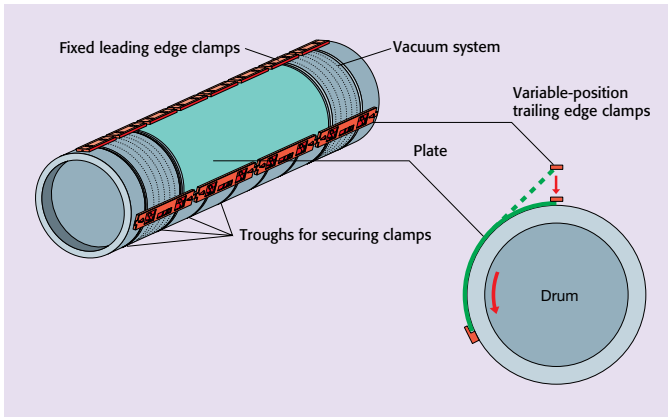

Achieving very high registration accuracy by an Automatic Inline Punching System

The PlateRite 8300S and PlateRite 8300E feature an automatic inline punching system that helps enable perfect register on press. Plates are punched by this automatic inline punching system immediately before loading on to the drum, ensuring that the plates are always in the same position irrespective of plate size and squareness. This results in extremely high registration accuracy.

By adding optional press punch blocks (up to 8 punch blocks can be mounted and selected according to plate sizes and press types), imaged plates can be loaded straight on to the press. This eliminates any further manual steps, ensures high registration accuracy and creates the foundation for perfect results on press. This whole process shortens press make ready time dramatically and massively improves the efficiency of the whole operation.



Compatible with 8-mm clamps

The PlateRite 8300S and PlateRite 8300E support the use of 8-mm clamps as well as common 12-mm clamps. Most web offset presses require smaller clamp sizes to ensure that the maximum imaging area is made available. By supporting 8-mm clamps the PlateRite 8300S and PlateRite 8300E are able to cover the requirements of both web and sheet-fed offset presses.

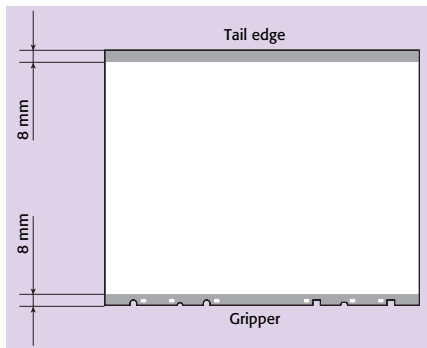

Space requirements

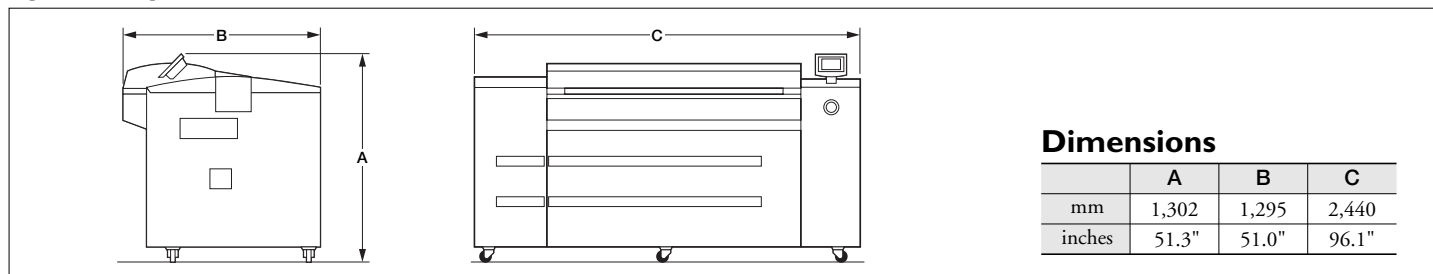

Dimensions

	A	B	C
mm	1,302	1,295	2,440
inches	51.3"	51.0"	96.1"

PlateRite 8300S/8300E specifications

Product name	PlateRite 8300S	PlateRite 8300E
Recording system	External drum	
Light source	32-channel infrared laser diodes	16-channel infrared laser diodes
Plate size	Maximum 1,160 x 940 mm (45.6" x 37") / Minimum 450 x 370 mm (17.8" x 14.6") (Supports B3 vertical size plates.) (Minimum plate size 304 x 370 mm [12.0" x 14.6"] with factory option)	
Exposure size	Maximum 1,160 x 924 mm (45.6" x 36.3") / Minimum 450 x 354 mm (17.8" x 14")*1 (Minimum exposure size 304 x 354 mm [12.0" x 14"] with factory option)	
Media	Thermal (infrared sensitive) plates	
Media thickness	0.15 to 0.3 mm (5.9 to 11.8 mil)*2	
Resolutions	1,200/2,000/2,400/2,438/2,540/4,000*3 dpi	2,400/2,438/2,540*3 dpi (outputs at 1,200 dpi resolution after upgrading)
Repeatability	±5 microns*4	
Productivity	13 plates/hr at 2,400 dpi (1,030 x 800 mm/40.5" x 31.4" plates)*5	8 plates/hr at 2,400 dpi (1,030 x 800 mm/40.5" x 31.4" plates)*5
Interface	Fast PIF	
Plate transport	Semi-automatic loading (standard) / Fully-automatic loading (optional)	
Punch systems (optional)	SCREEN, Heidelberg, Protocol, Komori, and others	
Dimensions (W x D x H)	2,440 x 1,295 x 1,302 mm (96.1" x 51.0" x 51.3")	
Weight	Approx. 1,150 kg (2,530 lb)	
Environment	Recommended environment 23°C ±2°C (73.4°F ±35.6°F), Operating environment 22°C ±4°C (71.6°F ±39.2°F), 40% to 70% relative humidity (non-condensing)	
Power requirements	Single phase 200 V to 240 V, 32 A, 4.0 kW*6	

*1 Use of 8-mm clamps results in 16-mm reduction of exposure size. Use of 12-mm clamps results in 24-mm reduction. Maximum drum speed of 600 rpm for 8-mm clamps or for plates smaller than 650 x 550 mm (25.6" x 21.7").

*2 Up to 0.4 mm thick as a factory option. *3 When outputting at 4,000 dpi, confirm output quality before use. *4 Over four consecutive exposures on one plate at 23°C (73.4°F) and 60% relative humidity.

*5 Output speed may vary depending on the sensitivity of the media and clamp size selection. *6 Also covers power requirements of SA-L, MA-L, AT-T, AT-M, and blower unit.

Autoloader specifications

Model name	MA-L8800II	SA-L8800II
Plate transport	Fully automatic loading and automatic interleaf removal	
Cassette capacity	100 plates per cassette	100 plates
No. of cassettes	3 cassettes (standard), additional 2 cassettes (optional)	-
Cassette transport	Fully-automatic (horizontal/vertical)	-
Cleaning function	Cleaning roller (cleans both sides of plate)	
Cassette changeover	2 minutes (between 1st and 5th cassette)	-
Dimensions (W x D x H)	3,213 x 1,806 x 1,295 mm (126.5" x 71.1" x 51.0")	1,758 x 1,806 x 1,295 mm (69.2" x 71.1" x 51.0")
Weight	1,250 kg (2,750 lb) Plate supply section: 530 kg (1,166 lb) Cassette collection section: 720 kg (1,584 lb)*1	600 kg (1,320 lb)
Power	Single phase 200 to 230 V ±10%, 5 A, 1.0 kW *2	
Environment	Recommended environment 23°C ±2°C (73.4°F ±35.6°F), Operating environment 22°C ±4°C (71.6°F ±39.2°F), 40% to 70% relative humidity (non-condensing)	
Standard accessories	3 cassettes, interleaf paper collection box	Plate cassette and carrier, Interleaf paper collection box
Options	Additional plate cassettes and carriers (with cassette dust covers)	

*1 Increases by 500 kg (1,100 lbs.) when fully loaded with cassettes and plates. *2 Powered by main unit.

DAINIPPON SCREEN MFG. CO., LTD.

HEAD OFFICE

• Teranouchi-agaru 4-chome, Horikawa-dori, Kamigyō-ku, Kyoto, 602-8585 Japan/Phone +81-75-414-7610/Fax +81-75-414-7608

SCREEN (USA)

• 5110 Tollview Dr., Rolling Meadows, IL 60008, USA/Phone 847-870-7400/Fax 847-870-0149 www.screenusa.com

DAINIPPON SCREEN (DEUTSCHLAND) GmbH

• Mündelheimer Weg 33, 40472 Düsseldorf, Germany/Phone 0211-4727199/Telex 858-4438 DSSDD D

DAINIPPON SCREEN (U.K.) LTD.

• Michigan Drive, Tongwell, Milton Keynes, Buckinghamshire MK15 8HT, UK/Phone 01908-848500/Fax 01908-848501 www.screen.co.uk

DAINIPPON SCREEN (NEDERLAND) BV

• Bouwerij 46, 1185XX Amstelveen, Holland/Phone 020-4567800/Fax 020-4567805 www.screeneurope.com

SCREEN FRANCE

• Z.I. Paris Nord II, 12 Rue des Chardonnerets, B.P. 50315, F-95940 ROISSY C.D.G. Cedex, France/Phone 1-48-17-86-00/Fax 1-48-17-86-01

DAINIPPON SCREEN SINGAPORE PTE. LTD.

• #29, Kaki Bukit View, Kaki Bukit Technopark II, Singapore 415963/Phone 67493833/Fax 67499010 www.screensp.com.sg

DAINIPPON SCREEN (CHINA) LTD.

• 6th Floor, 414 Kwun Tong Road, Kwun Tong, Kowloon, Hong Kong/Phone 2953-0038/Fax 2755-8683

Beijing office /Phone 010-6708-9271, 9272, 9273/Fax 010-6505-4975 (China)

Shanghai office /Phone 021-6466-4501/Fax 021-6466-4503 (China)

Guangzhou office/Phone 020-3891-1112/Fax 020-3891-1036 (China)

DAINIPPON SCREEN (TAIWAN) CO., LTD.

• 4F No. 126-1, Ming Tsu West Rd., Taipei, Taiwan/Phone 02-25862711/Fax 02-25914367

DAINIPPON SCREEN (KOREA) CO., LTD.

• 10th Yonsei Bldg, 9D-48-2, 1Ga, Bongnae-Dong, Joong-Gu, Seoul 100-161, Korea/Phone 02-7766-7868/Fax 02-7766-787

DAINIPPON SCREEN (AUSTRALIA) PTY. LTD.

• Unit 2, 207-209 Young Street, Waterloo, NSW 2017, Australia/Phone 02-9310-1314/Fax 02-9310-3566

Internet web site : www.screen.co.jp

www.screenusa.com

www.screeneurope.com

- This brochure was made using Spekta 2 screening.
- Printed on recycled paper.

We reserve the right to alter product design and specifications without prior notice.